

WARRANTY CARD

Model No.
 Serial No.
 C.M.No. Date of Sale.
 Owner's Name and Address.

 Tested By. Remarks.

AUTHORIZED DEALER/FRANCHISEE

COMPANY'S AUTHORIZED PRICE LIST FOR SPARES AVAILABLE WITH SERVICE FRANCHISEE



**MAHARAJA
WhatsApp**

Easy & Quickest Way to
Register a Complaint

www.maharajawhiteline.com

Follow us on:

Marketed by:

Groupe SEB India (P) Ltd.

C-67, 3rd Floor, DDA Sheds, Okhla Phase 1, New Delhi-110020, India

For customer feedback and complaints, please contact:

Service Executive: Groupe SEB India (P) Ltd.

C-67, 3rd Floor, DDA Sheds, Okhla Phase 1, New Delhi-110020, India

Tel : 8860505777, 8860555777

e-mail:maharajacare@groupeseb.com

Maharaja Whiteline is registered trademark of Groupe SEB India Pvt Limited.

MAHARAJA[®] —WHITELINE—

**3 YEARS
WARRANTY***
ON MOTOR & PUMP
FREE

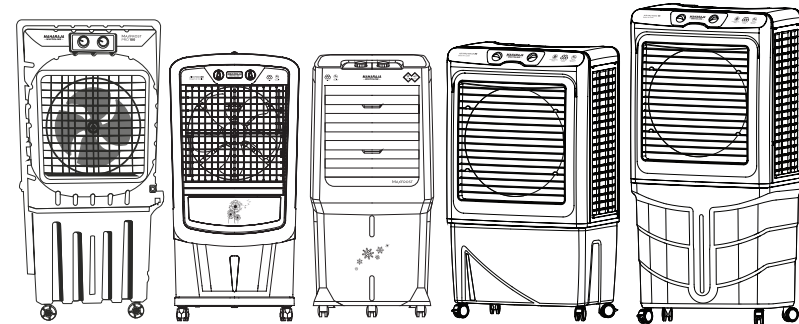

Air Coolers

INSTRUCTION MANUAL

How To Install And Operate Product

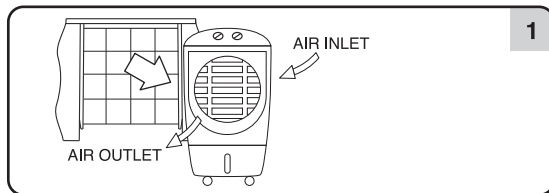

INSTALLATION

1. Place your cooler atleast 10cm away from wall or any other obstruction. The cooler should be placed near a window / door to allow fresh air.
2. Always ensure that there is another open window / door through which warm air can escape from the room. Constant air changes is very essential for fresh air cooling by your cooler.
3. Plug in the mains cord of your cooler to a wall socket. Ensure the plug is properly earthed and is in 'OFF' position while plugging.

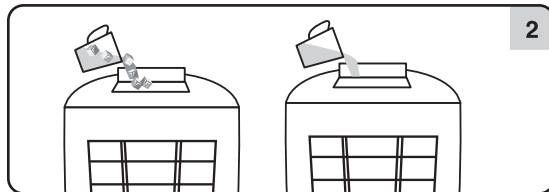

FILLING OF WATER

Fill water tank of the cooler with water through the water inlet door / ice lid. It is advisable to use tumbler to fill the water to avoid spillage. (Ensure the power point is 'OFF' while filling water)

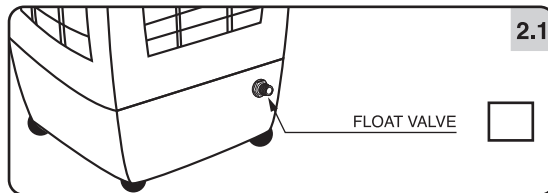

AUTOFILL

Float valve facility is available in selected models*. Make provision for automatic water filling to the cooler. Ensure proper connection of water inlet pipe into the float valve to avoid leakage.

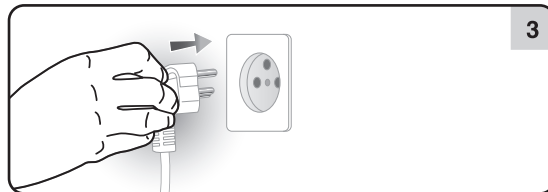

POWER SUPPLY

Ensure that your cooler is plugged into specified voltage / frequency outlet only. Switch 'ON' the power supply.

How To Install And Operate Product

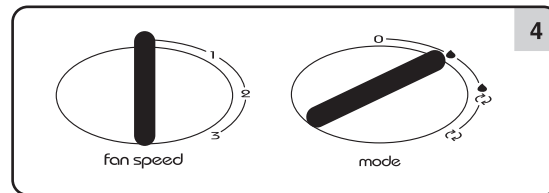

CONTROL

Switch on the pump of the cooler by first putting the control knob in cool position but keeping the air flow control in 'OFF' position. Wait for 5 minutes for the pad to get wet properly.**

** Not applicable for window cooler

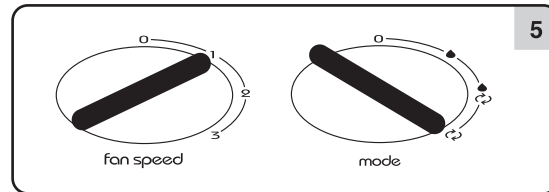

CONTROL

Set the air cooler to 'ON' position. Set the FAN SPEED knob to desired level that is 1, 2 or 3 for air delivery. If you want to use the cooler in COOL mode, set the MODE knob to swing(2) position to obtain continuous horizontal oscillation of air. Wait for the blast to focus in the direction you desire and then turn the MODE knob to '0'.

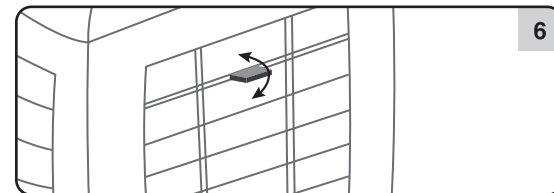

LOUVERS MOVEMENT

Adjust horizontal louvers manually as desired.

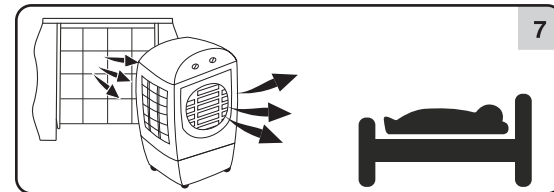

Keep the doors & windows open for optimum cooling performance. Always keep the cooler in front of an open window.

How To Operate Remote Control Model

CONTROLS

A. POWER ON/OFF: Press power button to turn on the unit. Only power LED will glow and remaining will shut off. Press power button again to turn off the unit.

B. SPEED: After plugging the cooler into the specified voltage, press the speed button to start & select the fan speed level in the following sequence High-Medium-Low & High-Low Specified LED will glow according to your selection.

C. SWING: In order to spread the air around the room press swing button. LED will glow when you press the swing button.

D. TIMER (For Remote models only): Press the timer button to set the desired timing level, the range of the timer is 1-7 hours. Specified LED will glow according to set time. No LED glow means, it is in continuous mode.

E. PUMP: In order to increase the cooling, press cool button. Ensure that the tank of the cooler is filled with water at required level before pressing the cool button. pecified LED will glow, when you press the cool button.

SAFETY PRECAUTIONS

- Always disconnect mains supply before filling water.
- Do not overfill the cooler.
- Do not try to fill the water into the cooler rapidly particularly when there is water in the tank.
- Do not move the cooler when there is water in the tank.
- Always disconnect mains before opening filter net or panels.
- Be particularly careful when using the cooler near curtains. Keep it at a safe distance from the curtains.

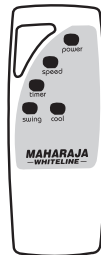

Care & Maintenance

Cleaning of cooler by draining the water

To drain the left over water from the tank pull to remove the drain plug given at the lower back side / bottom side of the tank. After draining, push to fix the drain plug properly.

It is advisable to drain water on regular basis for better performance & longer life of pads.

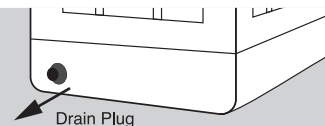

Trouble Shooting

Trouble	Cause	Remedy
Less Cooling	Pump is switched 'OFF'	Switch 'ON' the Pump
	No air circulation	Ensure cross ventilation
Water Leakage	Drain Plug is displaced	Ensure that the drain plug is positioned properly
	Grill lock is disengaged	Relock the grill
	Cooling pad is sagged	Change the cooling pads
Fan not working	Speed switch is turned 'OFF'	Switch 'ON' the fan by selecting the required speed
	Loose contact at socket	Rectify faulty wiring / Socket in the house
	Switch to Motor Malfunctioning	Call customer care help line
Sock on cooler	Device malfunction	Call customer care help line

** TOP Function
Motor & Pump have Inbuild Thermal Overheat Protection (T.O.P) for safety Purpose So in case of overheat they will stop operation to protect the winding from damage & will automatically restart after cooling to normal Temperature.

Care & Maintenance

CARE

1. When the cooler is not being used, make sure that all the switches are in the 'OFF' Position.
2. Operate all controls gently.
3. Do not wipe the cooler with corrosive chemicals, scrubbing powder or NC thinner as they will damage the finish.
4. Before moving or relocating the cooler ensure that the mains cord is unplugged and that the water tank is empty.
5. Do not keep heavy weight on top of the air cooler.
6. Do not add any bleaching agents to the water in the tank.

MAINTENANCE

1. Periodic maintenance helps to keep your air cooler in good condition.
2. We recommend draining the unit and cleaning the evaporative pads.
3. Stop the cooler and disconnect plug from the main socket, before cleaning.
4. Clean the evaporative pad using the house spray until the dust is removed, which would otherwise decrease the effectiveness of the cooler.
5. Replace the woodwool pad every year & Honeycomb pad every three years for efficient cooling.
6. After the summer season, ensure that the water is drained out completely from the tank.

How To Assemble The Leg & Castor Wheel

Slide the Leg / Castor into the tank as shown & fasten the screw both side. Insert the shaft of the wheel into the leg & tank recess & ensure it is fit firmly.

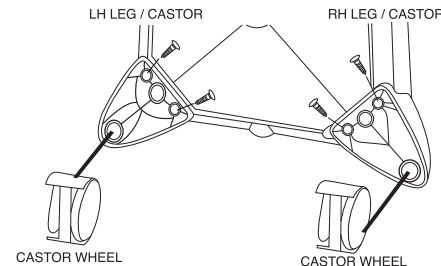

Wiring Diagrams

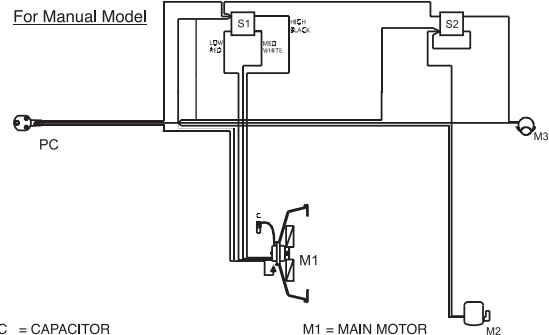

C = CAPACITOR
 S1 = SWITCH FOR FAN MOTOR
 S2 = SWITCH FOR PUMP/SWING MOTOR

M1 = MAIN MOTOR
 M2 = PUMP MOTOR
 M3 = SWING MOTOR

Supply Voltage: 230V AC / 50 Hz

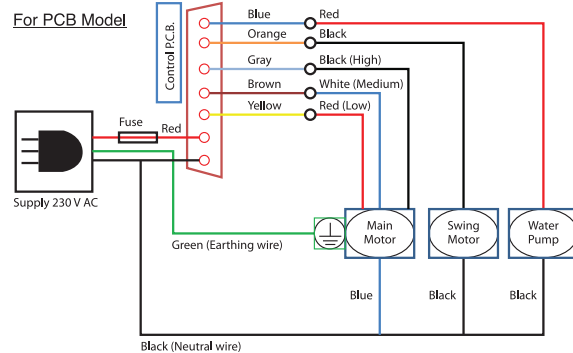

* Compatible with only Sine wave 50 Hz 230 V AC power supply.

Wiring Diagrams

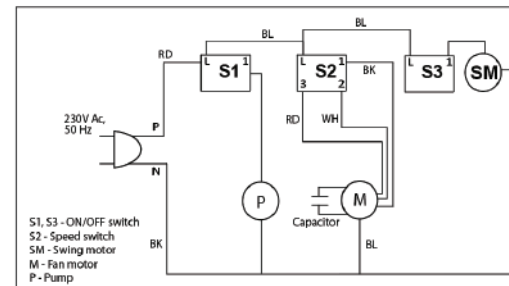

S1, S3 - ON/OFF switch
 S2 - Speed switch
 SM - Swing motor
 M - Fan motor
 P - Pump

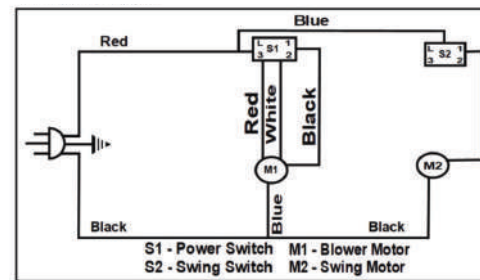

S1 - Power Switch
 S2 - Swing Switch
 M1 - Blower Motor
 M2 - Swing Motor

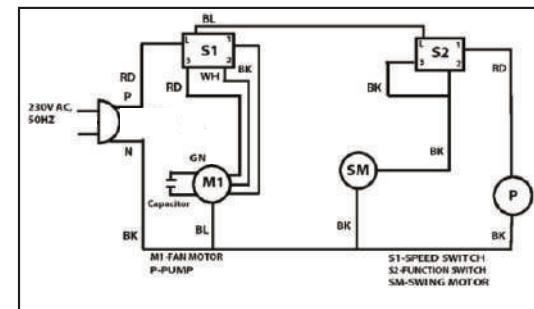

M1 - FAN MOTOR
 P - PUMP

S1 - SPEED SWITCH
 S2 - FUNCTION SWITCH
 SM - SWING MOTOR

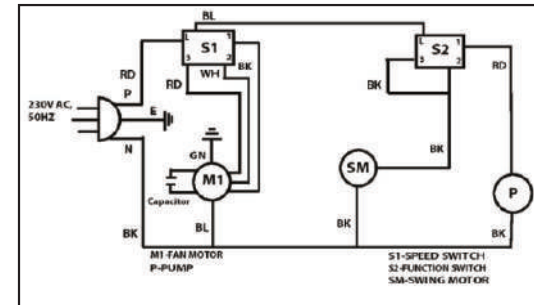

M1 - FAN MOTOR
 P - PUMP

S1 - SPEED SWITCH
 S2 - FUNCTION SWITCH
 SM - SWING MOTOR

Warranty Terms And Conditions

GROUPE SEB INDIA PVT LIMITED ("Company") warrants that the Company shall rectify any manufacturing defect in the Air-Cooler ("Product"), carry out such repair/replacement (as the case may be) free of charge during the warranty period of 1 (one) year. The Company shall in no event be replacing the product as a part of warranty unless and until there is an irreparable manufacturing defect in the product as decided by the technical team of the Company.

The period of availing warranty shall commence from the date of purchase as mentioned on the valid tax invoice or on Warranty card duly filled, signed & stamped by authorised dealer of the Company. The Company is not required to provide any services pertaining to the product after the expiry of said warranty period.

TERMS AND CONDITIONS OF WARRANTY:

1. This warranty shall be valid only if the product shall be used only as per the guidelines provided in this instruction manual. The product is to be used only for domestic purpose and not for any commercial, rental or profit generating activities.
2. This warranty is exclusively valid within territory of India, for products purchased therein.
3. This warranty can only be availed by the first purchaser of the product and is not transferable and non-assignable.
4. The Customer is required to register the complaint with the Customer Care Centre of the Company by way of phone call, email or Whatsapp Chatbot.
5. The customer must present the valid warranty card or the valid tax invoice as a pre-condition before available the warranty for the product as well as any related spares in the absence of which the Company may refuse to provide any warranty services.
6. Any repair or replacement done on the Product or any parts of the product during the warranty period, will in no event extend the Warranty period. The Warranty period is limited as provided herein, irrespective of the period of the product was not in use, was not giving proper performance, was under breakdown or was under repair by Company's authorised service centre.
7. The Company/its Authorised Service Centre reserves the right to retain any part/component/product replaced. The Company shall have exclusive right to replace the defective/unserviceable parts with the parts which may be new or refurbished free of charge during the warranty period.
8. Any repair or replacement carried out on the product or any part thereof by anyone other than authorised service centre, shall make this warranty void.
9. The Company shall provide Door-step service during the Warranty period. However, if the Product is located outside the municipal limits and serviceable area of Company's Authorised Service Centre, in such rare event the Company may refuse to provide Door-Step service and the Customer shall be required to bring the Product at the designated Service Centre of the Company or some other location within the municipal limits, at its own cost and expenses.
10. In case of any doubt regarding any conditions mentioned on this warranty card, including but not limited to authenticity of the Product, tax invoice, warranty card, part of the product etc, the decision of the Company shall be final and binding on the Customer.
11. The warranty is issued at New Delhi and courts at New Delhi shall have sole jurisdiction over matters covered or flowing from this warranty.
12. The Company shall not be liable for any indirect, special, consequential, special, incidental, punitive, exemplary or economical damage or loss. The Company's liability under or in relation to this warranty shall be limited to the purchase price paid by the Customer as per valid tax invoice.

1 YEAR comprehensive and 3 YEARS ON MOTOR AND PUMP.

- a. 3-years motor and pump warranty shall be applicable on Air Pro 60, Air Pro 80, Maxfrost 90, Maxfrost Pro 100, Air Pro Maxx 80 and Air Pro Maxx 115 Air Coolers purchased between 01st February 2026 and 31st July 2026
The 1 year comprehensive and 3 years on motor and pump.
- b. This 3-years warranty shall be applicable only on Fan motor and submersible pump and does not cover the other plastic parts and swing motor.
- c. For any claim received under this warranty, only motor and pump may be replaced free of cost, if found defective. The consumer must bear the standard visiting charges for service as per company policy. For repair or service of any other part, this extended warranty shall not be applicable, and Consumer shall bear standard repair/part replacement charges and visit charges.

Warranty Terms And Conditions

d. Customer may claim this 3 years motor and pump warranty by this warranty card. This warranty may be claimed basis stamp and date mentioned by dealer on this warranty card. Date should be within the limited time offer given by the company, i.e. between 01st February 2026 and 31st July 2026 .

THIS WARRANTY IS NOT APPLICABLE IN ANY OF THE FOLLOWING CASES:

- 1) The signed & stamped warranty card or the tax invoice is not presented to the service personnel at the time of claiming or availing the warranty.
- 2) The product installation, use or maintenance is not done as per the instructions given in this instruction manual or as per common sense/understanding of usage of air-cooler for such actions which are not specifically stated in this Instruction Manual.
- 3) If the original serial number of the Product is removed, tampered with or altered.
- 4) Violation of any warranty terms and conditions mentioned above.
- 5) The warranty doesn't apply to:
 - a) Plastic & rubber parts i.e. Tank, Front, side & back grills, Fan/blower, Main cord.
 - b) Normal wear and tear of the products and parts
 - c) Damages resulting from accidents, mishandling, improper usage, negligence on the part of consumer
 - d) Fluctuation in the supply voltage or usage of any power supply other than as specified on the Box
 - e) For humming sound generated by the Fan or motor
 - f) Failure of parts due to scale deposition
 - g) Complaint not registered at the Customer care centre of the Company by way of phone call, email or whatsapp chatbot within the warranty period